



















# Sonderwerkstoffe / Special materials

PPs		Seite
	Rohre / Pipe	
	Prod.Gruppen 705.....	176
	Bögen 90° / Bend 90°	
	Prod.Gruppe 001.....	177
	T-Stücke / Tee	
	Prod.Gruppe 006.....	178
	Vorschweißbunde / Stub flange	
	Prod.Gruppe 012.....	179
	Losflansche / Backing ring	
	Prod.Gruppe 014.....	180
	Reduktionen / Reducer	
	Prod.Gruppe 007.....	180

PPs-el		Seite
	Rohre / Pipe	
	Prod.Gruppen 705.....	182
	Bögen 90° / Bend 90°	
	Prod.Gruppe 001.....	183
	T-Stücke / Tee	
	Prod.Gruppe 006.....	184
	Vorschweißbunde / Stub flange	
	Prod.Gruppe 012.....	186
	Losflansche / Backing ring	
	Prod.Gruppe 014.....	187
	Reduktionen / Reducer	
	Prod.Gruppe 007.....	188

PE-el		Seite
	Rohre / Pipe	
	Prod.Gruppen 705.....	189
	MULTI-Bögen 90° / MULTI bend 90° <b>NEU</b>	
	Prod.Gruppe 068.....	190
	Bögen 90° / Bend 90°	
	Prod.Gruppe 001.....	191
	T-Stücke / Tee	
	Prod.Gruppe 006.....	192
	Vorschweißbunde / Stub flange	
	Prod.Gruppe 012.....	193
	Losflansche / Backing ring	
	Prod.Gruppe 014.....	195
	Reduktionen / Reducer	
	Prod.Gruppe 007.....	196

# Rohre / Pipe

aus PPs  
Standardlänge 5 m

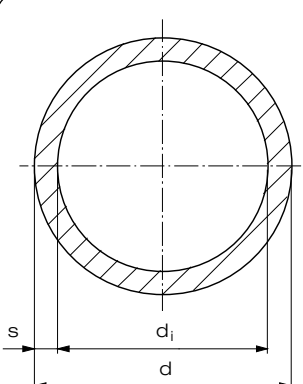
SDR 11				
	d	s	d <sub>i</sub>	kg/m
	20	2,0	16,2	0,12
	25	2,3	20,4	0,17
	32	3,0	26,2	0,27
	40	3,7	32,6	0,42
	50	4,6	40,8	0,65
	63	5,8	51,4	1,03
	75	6,8	61,4	1,44
	90	8,2	73,6	2,08
	110	10,0	90,0	3,09
	140	12,7	114,6	4,99
	160	14,6	130,8	6,55

Artikelgruppe PPs 17 705...

Art.-Nr.	€/m
0020 11	3,35
0025 11	4,35
0032 11	6,00
0040 11	8,00
0050 11	12,15
0063 11	19,00
0075 11	26,05
0090 11	37,55
0110 11	55,65
0140 11	86,35
0160 11	117,50

Rabattgruppe  
68

## Bögen 90° / Bend 90°

formgespritzt,  
r = d

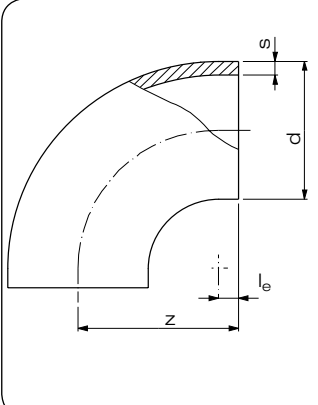
SDR 11	d	s	z	l <sub>e</sub>	VE <sup>1)</sup>
	20	2,5	32	10	240
	32	2,9	43	11	120
	40	3,7	46	6	80
	50	4,6	58	8	100
	63	5,8	70	7	50
	75	6,8	85	10	30
	90	8,2	100	10	16
	110	10,0	124	14	20
	140	12,7	150	10	10
	160	14,6	180	25	6

1) VE = Verpackungseinheit im Karton

Artikelgruppe	PPs	17 001...
Art.-Nr.	€/Stück	
0020 11	5,20	
0032 11	5,45	
0040 11	7,00	
0050 11	8,70	
0063 11	12,30	
0075 11	16,80	
0090 11	24,15	
0110 11	45,60	
0140 11	85,55	
0160 11	121,30	

Rabattgruppe  
53

## Bögen 90° / Bend 90°

formgespritzt,  
r = d

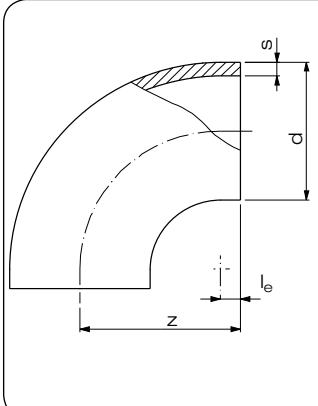
SDR 33	d	s	z	l <sub>e</sub>	VE <sup>1)</sup>
	110	3,4	120	10	20
	160	4,9	177	22	6
	180	5,5	200	20	5
	200	6,2	220	20	6
	225	6,9	245	20	5
	250	7,7	290	25	3
	280	8,6	290	25	3
	315	9,7	340	40	1
	355	10,9	340	40	1
	400	12,3	345	45	1

1) VE = Verpackungseinheit im Karton

Artikelgruppe	PPs	17 001...
Art.-Nr.	€/Stück	
0110 33	30,55	
0160 33	57,75	
0180 33	70,25	
0200 33	86,95	
0225 33	107,00	
0250 33	140,30	
0280 33	173,55	
0315 33	245,95	
0355 33	614,55	
0400 33	861,65	

Rabattgruppe  
53

## T-Stücke / Tee

verstärkt, formgespritzt

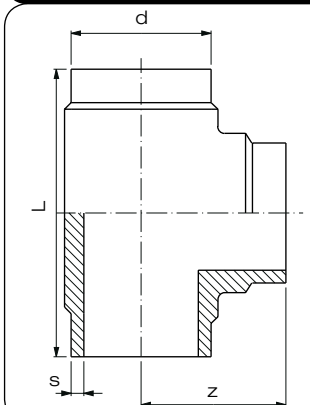
SDR 11	d	s	L	z	VE <sup>1)</sup>
	20	2,5	70	35	160
	25	2,7	78	40	200
	32	2,9	88	46	120
	40	3,7	90	50	50
	50	4,6	100	52	50
	63	5,8	125	65	30
	75	6,8	147	75	20
	90	8,2	207	106	8
	110	10,0	240	120	13
	140	12,7	293	145	6
	160	14,6	315	160	4

1)- VE = Verpackungseinheit im Karton

Artikelgruppe PPs 17 006...

Art.-Nr.	€/Stück
0020 11	4,20
0025 11	4,20
0032 11	5,20
0040 11	7,95
0050 11	10,60
0063 11	16,10
0075 11	32,25
0090 11	46,05
0110 11	70,20
0140 11	122,15
0160 11	205,05

Rabattgruppe  
53

## T-Stücke / Tee

verstärkt, formgespritzt

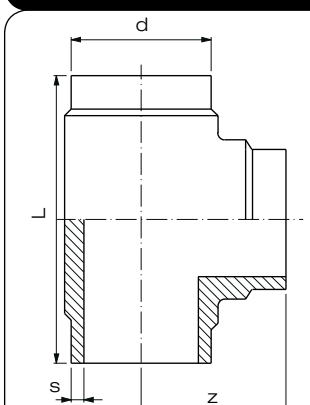
SDR 33	d	s	L	z	VE <sup>1)</sup>
	110	3,4	223	109	13
	160	4,9	346	173	4
	180	5,5	372	186	4
	200	6,2	405	202	3
	225	6,9	440	220	3
	250	7,7	475	237	3
	280	8,6	540	270	1
	315	9,7	550	275	1

1) VE = Verpackungseinheit im Karton

Artikelgruppe PPs 17 006...

Art.-Nr.	€/Stück
0110 33	40,00
0160 33	90,35
0180 33	120,75
0200 33	132,00
0225 33	246,90
0250 33	381,35
0280 33	485,65
0315 33	614,40

Rabattgruppe  
53

## Vorschweißbunde / Stub flange

formgespritzt

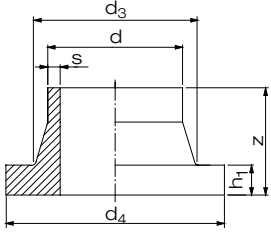
SDR 11	d	s	z	h <sub>1</sub>	d <sub>3</sub>	d <sub>4</sub>	VE <sup>1)</sup>
	20	1,9	52	7	27	45	160
	25	2,3	50	9	33	58	200
	32	2,9	50	10	40	68	40
	40	3,7	50	11	50	78	50
	50	4,6	50	12	61	88	80
	63	5,8	50	14	75	102	60
	75	6,8	50	16	89	122	40
	90	8,2	80	17	105	138	20
	110	10,0	80	18	125	158	40
	140	12,7	92	25	155	188	28
	160	14,6	92	25	175	212	20

1) VE = Verpackungseinheit im Karton

Artikelgruppe **PPs** 17 012...

Art.-Nr.	€/Stück
0020 11	4,75
0025 11	4,75
0032 11	5,35
0040 11	6,50
0050 11	7,80
0063 11	9,65
0075 11	11,25
0090 11	16,05
0110 11	20,65
0140 11	28,80
0160 11	36,25

Rabattgruppe 53

## Vorschweißbunde / Stub flange

formgespritzt

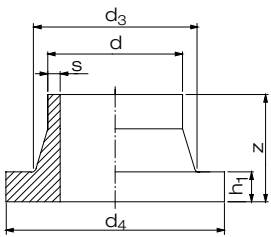
SDR 33	d	s	z	h <sub>1</sub>	d <sub>3</sub>	d <sub>4</sub>	VE <sup>1)</sup>
	110	3,4	80	18	125	158	40
	160	4,9	80	18	175	212	20
	180	5,5	92	18	183	212	20
	200	6,2	113	18	232	268	9
	225	6,9	113	18	235	268	9
	250	7,7	132	20	285	320	5
	280	8,6	128	20	291	320	5
	315	9,7	136	20	335	370	4
	355	10,9	120	23	373	430	10
	400	12,3	120	26	427	482	8
	500	15,3	120	33	530	585	6

1) VE = Verpackungseinheit im Karton

Artikelgruppe **PPs** 17 012...

Art.-Nr.	€/Stück
0110 33	18,80
0160 33	32,65
0180 33	47,65
0200 33	55,75
0225 33	63,85
0250 33	81,75
0280 33	96,65
0315 33	115,80
0355 33	381,15
0400 33	411,60
0500 33	585,30

Rabattgruppe 53

## Losflansche Typ „VB“ / Backing ring type „VB“ nach DIN 16962 / 16963-4 für Vorschweißbunde

PPs-el in Schwarz, glasfaserverstärkt,  
mit Stahleinlage, Lochbild nach DIN EN 1092-1, bis d 160 = PN 10/ PN 16;  
ab d 200 = PN 10

Artikelgruppe

PPs-el

19 014...

PN 10 / PN 16	Lochbild							VE <sup>1)</sup>
	d	DN	D	d <sub>6</sub>	k	d <sub>2</sub>	b	
bis d 315 bis PN 16 einsetzbar	32	25	115	42	85	4 x 14	16	30
	40	32	140	51	100	4 x 18	18	30
	50	40	150	62	110	4 x 18	18	16
	63	50	165	78	125	4 x 18	18	16
	75	65	187	92	145	4 x 18	18	15
	90	80	202	108	160	8 x 18	20	10
	110	100	220	128	180	8 x 18	20	11
	160	150	286	178	240	8 x 22	24	10
	200	200	340	235	295	8 x 22	24	5
	225	200	340	238	295	8 x 22	24	5
	250	250	409	288	350	12 x 22	30	lose
	315	300	463	338	400	12 x 22	34	lose

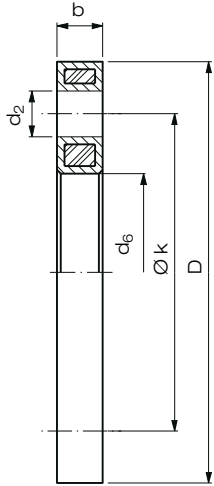

1) VE = Verpackungseinheit im Karton

Art.-Nr.	€/Stück
0032 11	18,65
0040 11	24,20
0050 11	27,40
0063 11	31,45
0075 11	34,95
0090 11	41,65
0110 11	66,10
0160 11	96,25
0200 11	123,50
0225 11	123,50
0250 11	196,75
0315 11	247,30

Rabattgruppe  
52

## Reduktionen / Reducer concentric

zentrisch,  
formgespritzt, stufenweise abgesetzt

Artikelgruppe

PPs

17 007...

SDR 11	d <sub>1</sub>	d <sub>2</sub>	s <sub>1</sub>	s <sub>2</sub>	L	VE <sup>1)</sup>
	63	16	5,8	1,8	55	200
	75	32	6,8	2,9	71	50
	110	63	10,0	5,8	62	30
	125	75	11,4	6,8	72	20
	160	110	14,6	10,0	83	8

1) VE = Verpackungseinheit im Karton

Art.-Nr.	€/Stück
6316 11	9,30
7532 11	14,60
1163 11	19,40
1275 11	22,00
1611 11	72,10

Rabattgruppe  
53

# Reduktionen / Reducer concentric

zentrisch,  
formgespritzt, stufenweise abgesetzt

SDR 33		d <sub>1</sub>	d <sub>2</sub>	s <sub>1</sub>	s <sub>2</sub>	L	VE <sup>1)</sup>
		110	63	3,4	2,0	97	50
		125	75	3,9	2,3	72	30
		160	110	4,9	3,4	83	18
		225	160	6,9	4,9	90	12
		315	225	9,7	6,9	130	10

1) VE = Verpackungseinheit im Karton

Artikelgruppe	PPs	17 007...
	Art.-Nr.	€/Stück
	1163 33	17,60
	1275 33	19,10
	1611 33	59,50
	2216 33	150,30
	3122 33	181,45

Rabattgruppe  
53

PE  
PP  
PVC/UC/TFE  
Sonderwerkstoffe  
PURAD  
Lüftung  
Flansche und Sonderteile  
Armaturen  
Doppelrohr  
Halbzeuge / Wickelrohr  
PKS, Schächte, Sure, Inspect RC  
Beton Schutzplatten  
Geothermie  
Schweißtechnik

## Rohre / Pipe

aus PPs-el schwarz, MOP 6bar  
Standardlänge 5 m

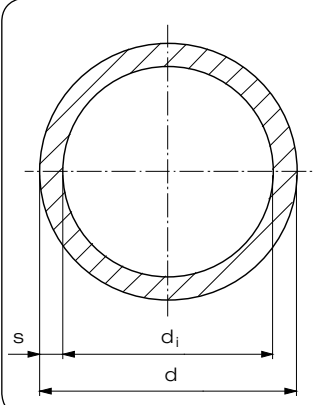
SDR 11				
	d	s	d <sub>i</sub>	kg/m
	32	3,0	26,2	0,32
	50	4,6	40,8	0,79
	63	5,8	51,4	1,25
	75	6,8	61,4	1,74
	90	8,2	73,6	2,51
	110	10,0	90,0	3,31

Artikelgruppe **PPs-el** 19 705...

Art.-Nr.	€/m
0032 11	12,10
0050 11	29,25
0063 11	46,15
0075 11	64,25
0090 11	92,60
0110 11	124,55

Rabattgruppe  
72

## Rohre / Pipe

aus PPs-el schwarz  
Standardlänge 5 m

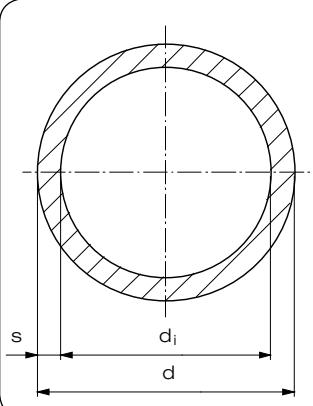
SDR 17,6				
	d	s	d <sub>i</sub>	kg/m
	110	6,3	97,4	2,46
	160	9,1	141,8	5,15
	200	11,4	177,2	8,05

Artikelgruppe **PPs-el** 19 705...

Art.-Nr.	€/m
0110 17	90,40
0160 17	189,65
0200 17	294,35

Rabattgruppe  
72

## Rohre / Pipe

aus PPs-el schwarz  
Standardlänge 5 m

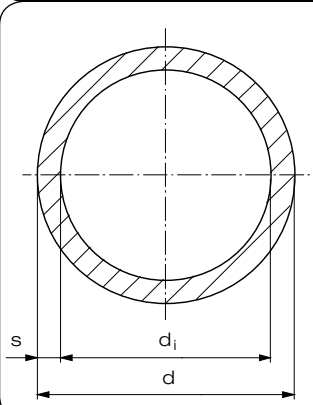
SDR 33				
	d	s	d <sub>i</sub>	kg/m
	90	2,8	84,4	0,93
	110	3,4	103,0	1,40
	160	4,9	150,2	2,90
	200	6,2	187,6	4,50
	225	6,9	211,2	5,86
	315	9,7	295,6	11,14

Artikelgruppe **PPs-el** 19 705...

Art.-Nr.	€/m
0090 33	33,55
0110 33	52,70
0160 33	107,70
0200 33	167,05
0225 33	206,95
0315 33	352,40

Rabattgruppe  
72



## Bögen 90° / Bend 90°

formgespritzt, MOP 6bar  
r = d

SDR 11					
	d	s	z	l <sub>e</sub>	VE <sup>1)</sup>
	32	2,9	43	11	120
	50	4,6	58	8	100
	63	5,8	70	7	50
	75	6,6	85	10	30
	90	8,2	100	10	16
	110	10,0	124	14	20

1) VE = Verpackungseinheit im Karton

Artikelgruppe	PPs-el	19 001...
Art.-Nr.	€/Stück	
0032 11	6,80	
0050 11	10,75	
0063 11	15,45	
0075 11	21,05	
0090 11	30,20	
0110 11	57,90	

Rabattgruppe  
52

## Bögen 90° / Bend 90°

formgespritzt,  
r = d

SDR 17					
	d	s	z	l <sub>e</sub>	VE <sup>1)</sup>
	110	6,6	123	13	20
	160	9,5	180	25	6
	200	11,9	220	20	6

1) VE = Verpackungseinheit im Karton

Artikelgruppe	PPs-el	19 001...
Art.-Nr.	€/Stück	
0110 17	55,90	
0160 17	113,55	
0200 17	172,20	

Rabattgruppe  
52

## Bögen 90° / Bend 90°

formgespritzt,  
r = d

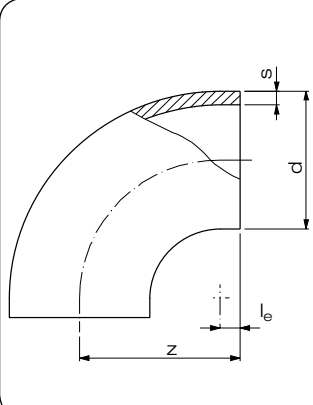
SDR 33	d	s	z	l <sub>e</sub>	VE <sup>1)</sup>
	110	3,4	120	10	20
	160	4,9	180	22	6
	200	6,2	220	20	6
	225	6,9	250	25	5
	250	7,7	290	25	3
	315	9,7	340	40	1

1) VE = Verpackungseinheit im Karton

Artikelgruppe PPs-el 19 001...

Art.-Nr.	€/Stück
0110 33	38,35
0160 33	72,70
0200 33	109,90
0225 33	135,05
0250 33	177,25
0315 33	310,80

Rabattgruppe  
52

## T-Stücke / Tee

verstärkt, MOP 6bar  
formgespritzt

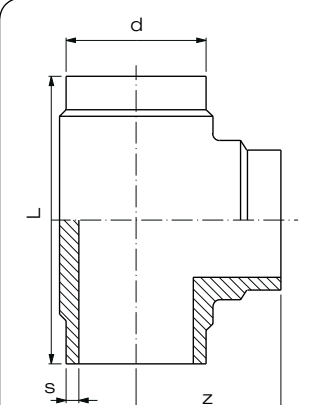
SDR 11	d	s	L	z	VE <sup>1)</sup>
	32	2,9	90	4	120
	50	4,6	120	60	50
	63	5,8	144	72	30
	75	6,8	152	75	20
	90	8,2	213	105	8
	110	10,0	253	122	12

1) VE = Verpackungseinheit im Karton

Artikelgruppe PPs-el 19 006...

Art.-Nr.	€/Stück
0032 11	6,20
0050 11	12,95
0063 11	20,30
0075 11	40,55
0090 11	60,40
0110 11	89,15

Rabattgruppe  
52

## T-Stücke / Tee

verstärkt,  
formgespritzt

SDR 17		d	s	L	z	VE <sup>1)</sup>
	110	6,6	251	121,0	13	
	160	9,5	346	173,0	4	
	200	11,9	405	202,5	4	

1) VE = Verpackungseinheit im Karton

Artikelgruppe PPs-el 19 006...

Art.-Nr.	€/Stück
0110 17	75,25
0160 17	230,90
0200 17	387,15

Rabattgruppe 52

## T-Stücke / Tee

verstärkt,  
formgespritzt

SDR 33		d	s	L	z	VE <sup>1)</sup>
	110	3,4	223	109,0	13	
	160	4,9	346	173,0	4	
	200	6,2	405	202,5	6	
	225	6,9	440	220,0	3	
	250	7,7	475	237,0	3	
	315	9,7	550	275,0	1	

1) VE = Verpackungseinheit im Karton

Artikelgruppe PPs-el 19 006...

Art.-Nr.	€/Stück
0110 33	50,20
0160 33	113,80
0200 33	177,95
0225 33	311,90
0250 33	482,30
0315 33	774,40

Rabattgruppe 52

## Vorschweißbunde / Stub flange

formgespritzt, MOP 6bar

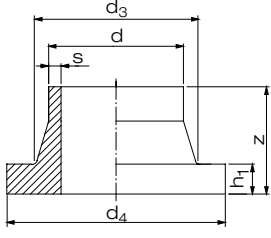
SDR 11	d	s	z	h <sub>1</sub>	d <sub>3</sub>	d <sub>4</sub>	VE <sup>1)</sup>
	32	2,9	50	10	40	68	80
	50	4,6	50	12	61	88	80
	63	5,8	50	14	75	102	60
	75	6,8	50	16	89	122	40
	90	8,2	80	17	105	138	20
	110	10,0	80	18	125	158	40

1) VE = Verpackungseinheit im Karton

Artikelgruppe PPs-el 19 012...

Art.-Nr.	€/Stück
0032 11	6,55
0050 11	9,65
0063 11	11,95
0075 11	14,05
0090 11	20,10
0110 11	25,90

Rabattgruppe  
52

## Vorschweißbunde / Stub flange

formgespritzt

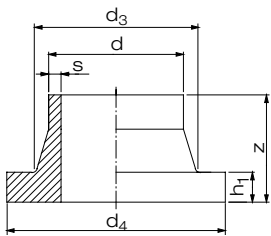
SDR 17	d	s	z	h <sub>1</sub>	d <sub>3</sub>	d <sub>4</sub>	VE <sup>1)</sup>
	110	6,6	80	18	125	158	40
	160	9,5	92	18	175	212	20
	200	11,9	110	24	232	268	8

1) VE = Verpackungseinheit im Karton

Artikelgruppe PPs-el 19 012...

Art.-Nr.	€/Stück
0110 17	23,40
0160 17	40,90
0200 17	74,60

Rabattgruppe  
52

# Vorschweißbunde / Stub flange

formgespritzt

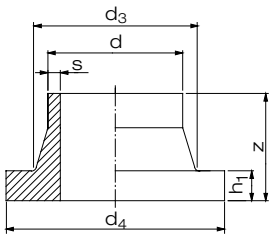
SDR 33	d	s	z	h <sub>1</sub>	d <sub>3</sub>	d <sub>4</sub>	VE <sup>1)</sup>
	110	3,4	80	18	125	158	40
	160	4,9	80	18	175	212	18
	200	6,2	113	18	232	268	8
	225	6,9	113	18	235	268	8
	250	7,7	132	20	285	320	5
	315	9,7	136	20	335	370	4

1) VE = Verpackungseinheit im Karton

Artikelgruppe PPs-el 19 012...

Art.-Nr.	€/Stück
0110 33	23,40
0160 33	40,90
0200 33	71,75
0225 33	80,55
0250 33	113,35
0315 33	146,20

Rabattgruppe 52

# Losflansche Typ „VB“ / Backing ring type „VB“ nach DIN 16962 / 16963-4 für Vorschweißbunde

PPs-el in Schwarz, glasfaserverstärkt,  
mit Stahleinlage, Lochbild nach DIN EN 1092-1, bis d 160 = PN 10/ PN 16;  
ab d 200 = PN 10

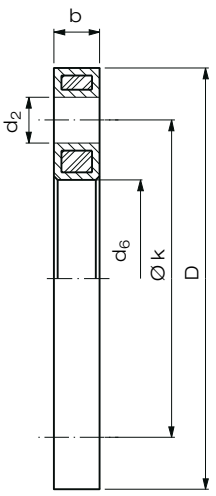
PN 10 / PN 16	Lochbild							VE <sup>1)</sup>	
	d	DN	D	d <sub>6</sub>	k	d <sub>2</sub>	b		
	bis d 315 bis PN 16 einsetzbar	32	25	115	42	85	4 x 14	16	30
		40	32	140	51	100	4 x 18	18	30
		50	40	150	62	110	4 x 18	18	16
		63	50	165	78	125	4 x 18	18	16
		75	65	187	92	145	4 x 18	18	15
		90	80	202	108	160	8 x 18	20	10
		110	100	220	128	180	8 x 18	20	11
		160	150	286	178	240	8 x 22	24	10
		200	200	340	235	295	8 x 22	24	5
		225	200	340	238	295	8 x 22	24	5
		250	250	409	288	350	12 x 22	30	lose
		315	300	463	338	400	12 x 22	34	lose

1) VE = Verpackungseinheit im Karton

Artikelgruppe PPs-el 19 014...

Art.-Nr.	€/Stück
0032 11	18,65
0040 11	24,25
0050 11	27,40
0063 11	31,45
0075 11	34,95
0090 11	41,65
0110 11	66,10
0160 11	96,25
0200 11	123,50
0225 11	123,50
0250 11	196,75
0315 11	247,30

Rabattgruppe 52

## Reduktionen / Reducer concentric

zentrisch,  
formgespritzt, stufenweise abgesetzt, MOP 6bar

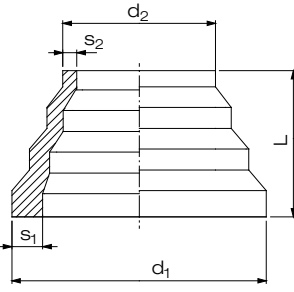
SDR 11	$d_1$	$d_2$	$s_1$	$s_2$	L	VE <sup>1)</sup>
	63	16	5,8	2	97	200
	75	32	6,8	3	71	50
	110	63	10,0	6	62	30

1) VE = Verpackungseinheit im Karton

Artikelgruppe PPs-el 19 007...

Art.-Nr.	€/Stück
6316 11	11,65
7532 11	18,35
1163 11	24,30

Rabattgruppe  
52

## Reduktionen / Reducer concentric

zentrisch,  
formgespritzt, stufenweise abgesetzt

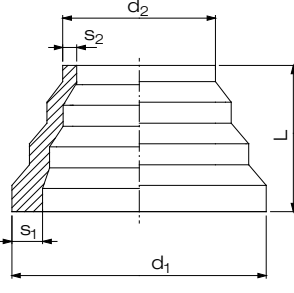
SDR 17	$d_1$	$d_2$	$s_1$	$s_2$	L	VE <sup>1)</sup>
	160	110	9,5	6,6	83	10
	225	160	13,4	9,5	90	18

1) VE = Verpackungseinheit im Karton

Artikelgruppe PPs-el 19 007...

Art.-Nr.	€/Stück
1611 17	80,15
2216 17	223,20

Rabattgruppe  
52

## Reduktionen / Reducer concentric

zentrisch,  
formgespritzt, stufenweise abgesetzt

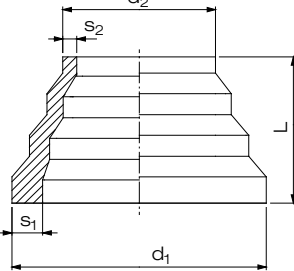
SDR 33	$d_1$	$d_2$	$s_1$	$s_2$	L	VE <sup>1)</sup>
	160	110	4,9	3,4	83	10
	225	160	6,9	4,9	90	12
	315	225	9,7	6,9	130	10

1) VE = Verpackungseinheit im Karton

Artikelgruppe PPs-el 19 007...

Art.-Nr.	€/Stück
1611 33	78,85
2216 33	198,85
3122 33	229,25

Rabattgruppe  
52

## Rohre / Pipe

aus PE-el schwarz  
Standardlänge 5 m

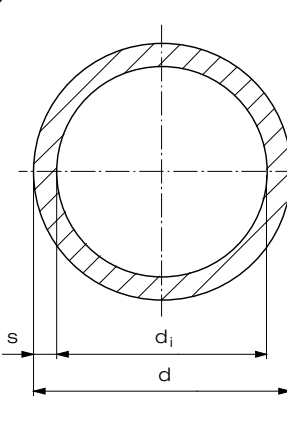
SDR 11				
	d	s	d <sub>i</sub>	kg/m
	32	3,0	26,2	0,3
	40	3,7	32,6	0,5
	50	4,6	40,8	0,7
	63	5,8	51,4	1,1
	75	6,8	61,4	1,5
	90	8,2	73,6	2,2
	110	10,0	90,0	3,3
	125	11,4	102,2	4,2
	160	14,6	130,8	7,0
	180	16,4	147,2	8,8
	200	18,2	163,6	10,8
	225	20,5	184,0	13,7
	250	22,7	204,6	16,8
	315	28,6	257,8	26,7

Artikelgruppe PE-el 28 705...

Art.-Nr.	€/m
0032 11	7,25
0040 11	11,35
0050 11	17,30
0063 11	27,45
0075 11	38,00
0090 11	54,50
0110 11	81,15
0125 11	104,45
0160 11	171,50
0180 11	215,85
0200 11	266,50
0225 11	337,80
0250 11	414,25
0315 11	658,20

Rabattgruppe 110

## Rohre / Pipe

aus PE-el schwarz  
Standardlänge 5 m

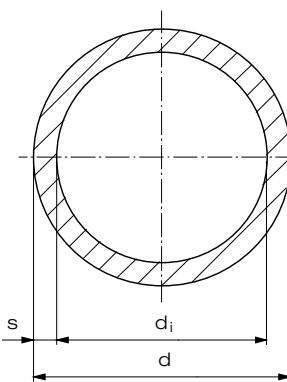
SDR 17,6				
	d	s	d <sub>i</sub>	kg/m
	90	5,1	79,8	1,4
	110	6,3	97,4	2,2
	125	7,1	110,8	2,8
	160	9,1	141,8	4,5
	180	10,2	159,6	5,7
	200	11,4	177,2	7,0
	225	12,8	199,4	8,9
	250	14,2	221,6	11,0
	315	17,9	279,2	17,4

Artikelgruppe PE-el 28 705...

Art.-Nr.	€/m
0090 17	35,70
0110 17	53,30
0125 17	68,25
0160 17	111,40
0180 17	140,20
0200 17	173,70
0225 17	219,90
0250 17	271,30
0315 17	429,10

Rabattgruppe 110

# Rohre / Pipe

aus PE-el schwarz  
Standardlänge 5 m

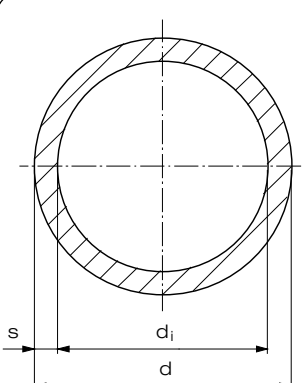
SDR 33				
	d	s	d <sub>i</sub>	kg/m
	110	3,4	103,0	1,2
	125	3,9	117,2	1,6
	160	4,9	150,2	2,5
	180	5,5	169,0	3,2
	200	6,2	187,6	4,0
	225	6,9	211,2	5,0
	250	7,7	234,6	6,2
	315	9,7	295,6	9,8
	400	12,3	375,4	15,6

Artikelgruppe PE-el 28 705...

Art.-Nr.	€/m
0110 33	30,10
0125 33	39,30
0160 33	62,60
0180 33	78,90
0200 33	98,20
0225 33	123,00
0250 33	152,35
0315 33	240,65
0400 33	384,65

Rabattgruppe 110

# MULTI-Bögen 90° / MULTI bend 90°

**NEU**

formgespritzt,  
mit langen Schweißenden,  $r \approx d$

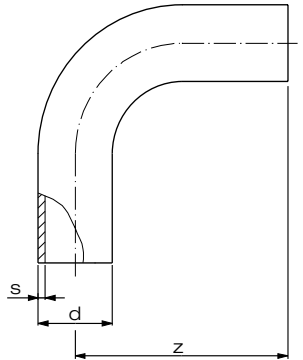
SDR 11				
	d	s	z	VE <sup>1)</sup>
	32	2,9	79,0	50
	40	3,7	92,5	30
	50	4,6	108,5	40
	63	5,8	129,5	20
	75	6,8	150,0	14
	90	8,2	168,0	8
	110	10,0	192,0	14

Artikelgruppe PE-el 28 068...

Art.-Nr.	€/Stück
0032 11	6,90
0040 11	9,45
0050 11	12,10
0063 11	18,15
0075 11	26,00
0090 11	38,60
0110 11	70,15

Rabattgruppe 54

1) VE = Verpackungseinheit



# MULTI-Bögen 90° / MULTI bend 90°

**NEU**

formgespritzt,  
mit langen Schweißenden,  $r \approx d$

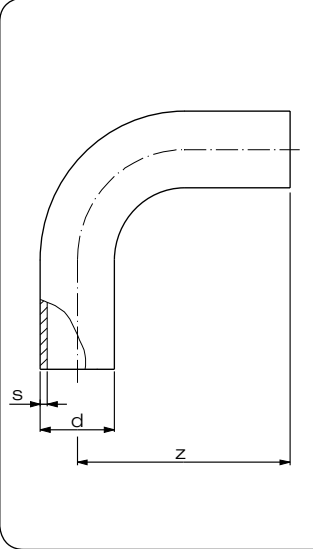
SDR 17	d	s	z	VE <sup>1)</sup>
	110	6.6	192	14

1) VE = Verpackungseinheit

Artikelgruppe PE-el 28 068...

Art.-Nr.	€/Stück
0110 17	64,65

Rabattgruppe 54

# Bögen 90° / Bend 90°

formgespritzt,  
 $r = d$

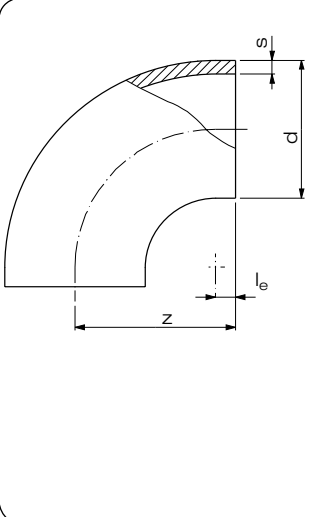
SDR 11	d	s	z	l <sub>e</sub>	VE <sup>1)</sup>
	32	2,9	43	11	120
	40	3,7	46	6	80
	50	4,6	58	8	100
	63	5,8	70	7	50
	75	6,8	85	10	30
	90	8,2	100	10	16
	110	10,0	124	14	20
	125	11,4	140	15	15
	160	14,6	180	25	6
	180	16,4	200	20	5
	200	18,2	220	20	6
	225	20,5	243	18	5
	250	22,7	290	25	3
	315	28,6	340	40	1

1) VE = Verpackungseinheit im Karton

Artikelgruppe PE-el 28 001...

Art.-Nr.	€/Stück
0032 11	6,45
0040 11	8,30
0050 11	10,35
0063 11	14,60
0075 11	20,15
0090 11	29,05
0110 11	55,25
0125 11	77,70
0160 11	126,30
0180 11	160,20
0200 11	223,25
0225 11	284,35
0250 11	510,80
0315 11	824,05

Rabattgruppe 54

## Bögen 90° / Bend 90°

formgespritzt,  
r = d

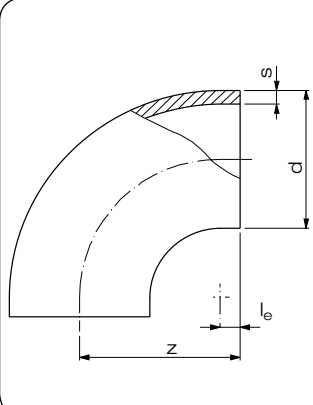
SDR 17	d	s	z	l <sub>e</sub>	VE <sup>1)</sup>
	110	6,6	123	11	20
	125	7,4	140	15	15
	160	9,5	180	25	6
	180	10,7	200	20	5
	200	11,9	220	20	6
	225	13,4	245	20	5
	250	14,8	285	20	3
	315	18,7	335	35	1

1) VE = Verpackungseinheit im Karton

Artikelgruppe PE-el 28 001...

Art.-Nr.	€/Stück
0110 17	53,85
0125 17	68,50
0160 17	109,20
0180 17	135,00
0200 17	167,55
0225 17	219,85
0250 17	347,30
0315 17	625,25

Rabattgruppe  
54

## T-Stücke / Tee

verstärkt,  
formgespritzt

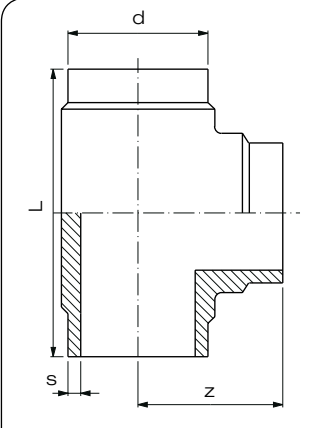
SDR 11	d	s	L	z	VE <sup>1)</sup>
	32	2,9	90	45,0	150
	40	3,7	100	50,0	50
	50	4,6	120	60,0	50
	63	5,8	144	72,0	30
	75	6,8	152	75,0	20
	90	8,2	213	105,0	8
	110	10,0	253	122,0	13
	125	11,4	280	140,0	8
	160	14,6	340	170,0	4
	180	16,4	365	182,5	3
	200	18,2	400	200,0	4
	225	20,5	440	220,0	3
	250	22,7	470	235,0	3
	315	28,6	540	270,0	1

1) VE = Verpackungseinheit im Karton

Artikelgruppe PE-el 28 006...

Art.-Nr.	€/Stück
0032 11	6,35
0040 11	9,35
0050 11	12,65
0063 11	19,45
0075 11	38,95
0090 11	58,00
0110 11	85,10
0125 11	117,05
0160 11	249,05
0180 11	320,00
0200 11	434,60
0225 11	545,20
0250 11	691,55
0315 11	1.328,00

Rabattgruppe  
54

## T-Stücke / Tee

verstärkt,  
formgespritzt

SDR 17		d	s	L	z	VE <sup>1)</sup>	
		110	6,6	249	121,0	13	
		125	7,4	270	135,0	8	
		160	9,5	340	170,0	4	
		180	10,7	365	182,5	4	
		200	11,9	400	200,0	4	
		225	13,4	440	220,0	3	
		250	14,8	470	235,0	3	
		315	18,7	550	275,0	1	

1) VE = Verpackungseinheit im Karton

Artikelgruppe PE-el 28 006...

Art.-Nr.	€/Stück
0110 17	72,35
0125 17	100,45
0160 17	222,00
0180 17	272,75
0200 17	356,60
0225 17	436,90
0250 17	579,70
0315 17	871,40

Rabattgruppe 54

## Vorschweißbunde / Stub flange

formgespritzt

SDR 11		d	s	z	h <sub>1</sub>	d <sub>3</sub>	d <sub>4</sub>	VE <sup>1)</sup>
		32	2,9	50	10	40	68	40
		40	3,7	50	11	50	78	50
		50	4,6	50	12	61	88	80
		63	5,8	50	14	75	102	60
		75	6,8	50	16	89	122	40
		90	8,2	80	17	105	138	20
		110	10,0	80	18	125	158	40
		125	11,4	80	25	132	158	30
		160	14,6	92	25	175	212	18
		180	16,4	93	30	183	212	18
		200	18,2	115	32	232	268	8
		225	20,5	113	32	235	268	7
		250	22,7	132	35	285	320	5
		315	28,6	136	35	335	370	4

1) VE = Verpackungseinheit im Karton

Artikelgruppe PE-el 28 012...

Art.-Nr.	€/Stück
0032 11	6,40
0040 11	7,30
0050 11	9,25
0063 11	11,45
0075 11	13,70
0090 11	19,30
0110 11	25,20
0125 11	29,85
0160 11	46,60
0180 11	67,80
0200 11	90,90
0225 11	88,85
0250 11	134,50
0315 11	196,60

Rabattgruppe 54

## Vorschweißbunde / Stub flange

formgespritzt

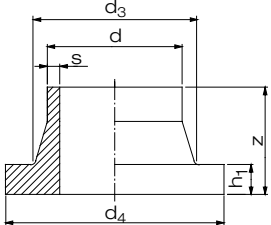
SDR 17	d	s	z	h <sub>1</sub>	d <sub>3</sub>	d <sub>4</sub>	VE <sup>1)</sup>
	110	6,6	80	18	125	158	40
	125	7,4	84	18	132	158	30
	160	9,5	92	18	175	212	20
	180	10,7	92	20	183	212	18
	200	11,9	110	24	232	268	9
	225	13,4	113	24	235	268	7
	250	14,8	132	25	285	320	5
	315	18,7	136	25	335	370	4

1) VE = Verpackungseinheit im Karton

Artikelgruppe PE-el 28 012...

Art.-Nr.	€/Stück
0110 17	22,45
0125 17	27,60
0160 17	39,50
0180 17	57,45
0200 17	71,90
0225 17	80,40
0250 17	114,70
0315 17	154,15

Rabattgruppe 54

## Vorschweißbunde / Stub flange

formgespritzt

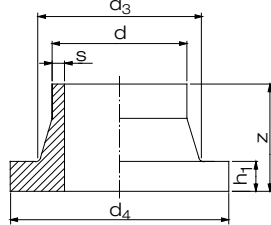
SDR 33	d	s	z	h <sub>1</sub>	d <sub>3</sub>	d <sub>4</sub>	VE <sup>1)</sup>
	110	3,4	80	18	125	158	40
	125	3,9	80	18	132	158	30
	160	4,9	80	18	175	212	20
	180	5,5	92	18	183	212	18
	200	6,2	113	18	232	268	9
	225	6,9	113	18	235	268	7
	250	7,7	132	20	285	320	5
	315	9,7	136	20	335	370	4
	355	10,9	150	23	373	430	7
	400	12,3	155	26	427	482	8

1) VE = Verpackungseinheit im Karton

Artikelgruppe PE-el 28 012...

Art.-Nr.	€/Stück
0110 33	22,45
0125 33	27,60
0160 33	39,50
0180 33	57,40
0200 33	69,00
0225 33	77,60
0250 33	109,35
0315 33	141,00
0355 33	240,80
0400 33	499,95

Rabattgruppe 54

# Losflansche Typ „VB“ / Backing ring type „VB“ nach DIN 16962 / 16963-4 für Vorschweißbunde

PPs-el in Schwarz, glasfaserverstärkt,  
mit Stahleinlage, Lochbild nach DIN EN 1092-1, bis d 160 = PN 10/ PN 16;  
ab d 200 = PN 10

Artikelgruppe

PPs-el

19 014...

PN 10 / PN 16	d	DN	D	d <sub>6</sub>	Lochbild k	d <sub>2</sub>	b	VE <sup>1)</sup>
bis d 315 bis PN 16 einsetzbar	32	25	115	42	85	4 x 14	16	30
	40	32	140	51	100	4 x 18	18	30
	50	40	150	62	110	4 x 18	18	16
	63	50	165	78	125	4 x 18	18	16
	75	65	187	92	145	4 x 18	18	15
	90	80	202	108	160	8 x 18	20	10
	110	100	220	128	180	8 x 18	20	11
	160	150	286	178	240	8 x 22	24	10
	200	200	340	235	295	8 x 22	24	5
	225	200	340	238	295	8 x 22	24	5
	250	250	409	288	350	12 x 22	30	lose
	315	300	463	338	400	12 x 22	34	lose

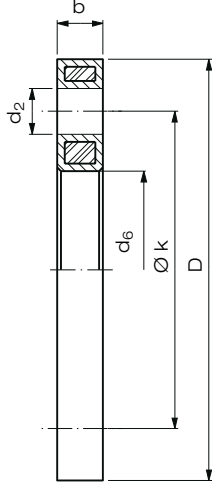

1) VE = Verpackungseinheit im Karton

Art.-Nr.	€/Stück
0032 11	18,65
0040 11	24,25
0050 11	27,40
0063 11	31,45
0075 11	34,95
0090 11	41,65
0110 11	66,10
0160 11	96,25
0200 11	123,50
0225 11	123,50
0250 11	196,75
0315 11	247,30

Rabattgruppe  
52

## Reduktionen / Reducer concentric

zentrisch,  
formgespritzt, stufenweise abgesetzt

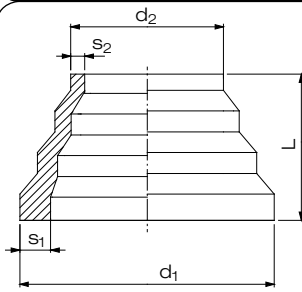
SDR 11	d <sub>1</sub>	d <sub>2</sub>	s <sub>1</sub>	s <sub>2</sub>	L	VE <sup>1)</sup>
	63	16	5,8	1,8	55	200
	110	63	10,0	5,8	63	30
	160	110	14,6	10,0	84	8
	225	160	20,5	14,6	90	15
	315	225	28,6	20,5	130	5

1) VE = Verpackungseinheit im Karton

Artikelgruppe PE-el 28 007...

Art.-Nr.	€/Stück
6316 11	11,25
1163 11	23,45
1611 11	87,35
2216 11	236,35
3122 11	261,20

Rabattgruppe  
54

## Reduktionen / Reducer concentric

zentrisch,  
formgespritzt, stufenweise abgesetzt

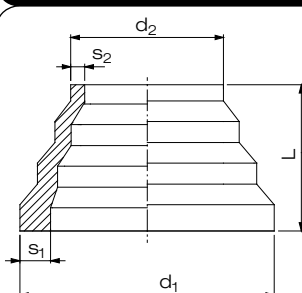
SDR 17	d <sub>1</sub>	d <sub>2</sub>	s <sub>1</sub>	s <sub>2</sub>	L	VE <sup>1)</sup>
	160	110	9,5	6,6	83	10
	225	160	13,4	9,5	90	18
	315	225	18,7	13,4	130	6

1) VE = Verpackungseinheit im Karton

Artikelgruppe PE-el 28 007...

Art.-Nr.	€/Stück
1611 17	81,55
2216 17	214,70
3122 17	243,25

Rabattgruppe  
54